

# NR01 4-component NET - Radiation sensor

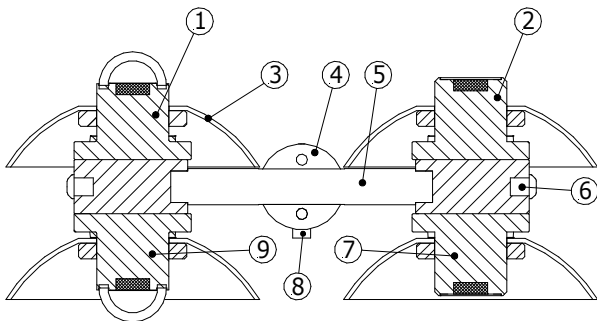
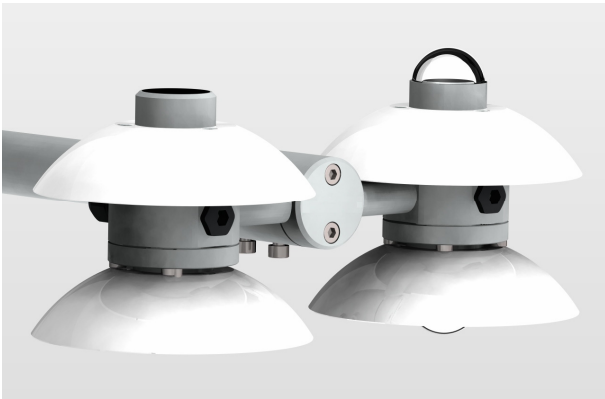

Figure 1 NR01 4-component net radiation sensor. SW solar radiation sensor or pyranometer (1), LW Far Infra-Red radiation sensor or pyrgeometer (2), radiation shield (3), levelling assembly for x- and y axis (4, 5 and 8).

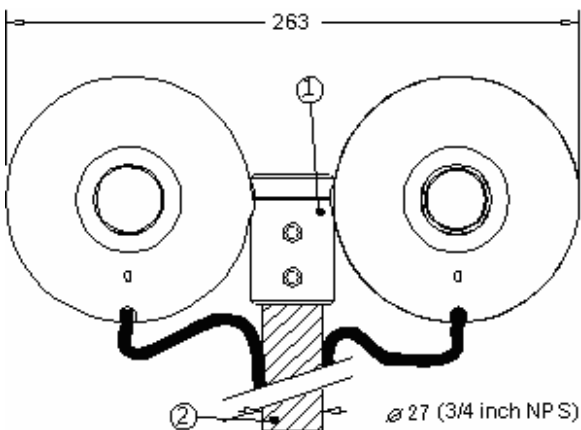

Figure 2 NR01 top view. Standard cable length is 5 m. Cable can be installed / replaced by the user. Attachment to a 1 inch tube (2), not included, is extremely easy, levelling possibilities are included. Dimensions in mm.

NR01 is a 4-component net-radiation sensor that is used for scientific-grade energy balance studies. The instrument has separate measurements of solar (Short Wave or SW) and Far Infra-Red (Long Wave or LW) radiation. Major improvements relative to comparable instruments include weight (reduced), solar offsets in the LW signal (reduced), ease of leveling (high, because levelling assembly is included).

NR01 serves to measure the 4 separate components of the surface radiation balance. Working completely passive, using a thermopile sensors, NR01 generates 4 small output voltage proportional to the incoming and outgoing SW and LW fluxes. The SW solar radiation sensors are also called pyranometers, the LW sensors are also called pyrgeometers. For calculation of sky- and surface temperature, a thermister temperature sensor is included in the pyrgeometers.

In order to avoid deposition of dew, the pyrgeometers may be heated. A 2-axis levelling assembly is included.

The NR01 cable can easily be installed or replaced by the user. See also RA01 radiameter on the next page, which is a single side version of NR01. Combined with estimates of SW albedo- and of surface temperature, this instrument can also be used for estimation of net-radiation.

## NR01 SPECIFICATIONS

General:

Temperature range:	-40 to +80 °C
Range :	0 to 2000 Wm <sup>-2</sup>
Temperature sensor:	Thermister
Temperature sensor:	users own preference can be plugged in

Pyranometer (SW):

Pyranometer ISO classification:	second class
Spectral range:	305 to 2800 nm
Calibration traceability:	WRR

Pyrgeometer (LW):

Spectral range:	4500 to 50000 nm
Calibration traceability:	NIST
Window heating offset	
@ 1000 Wm <sup>-2</sup> solar radiation:	<15 Wm <sup>-2</sup>
heating power:	5 Watt @12VDC

## OPTIONS

Additional cable length x metres (add to 5m)

The above specifications are subject to change without further notice

# RA01 2-component Radiation sensor

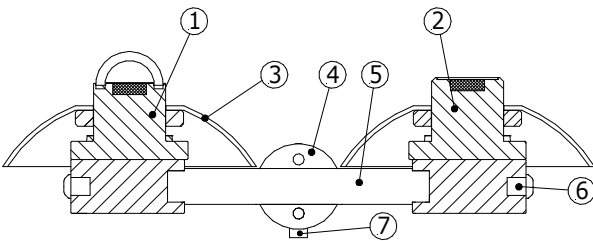
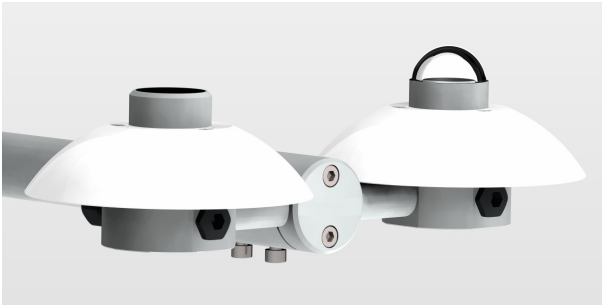

Figure 1 RA01 2-component radiation sensor. SW solar radiation sensor or pyranometer (1), LW Far Infra-Red radiation sensor or pyrgeometer (2), radiation shield (3), levelling assembly for x- and y axis (4, 5 and 7).

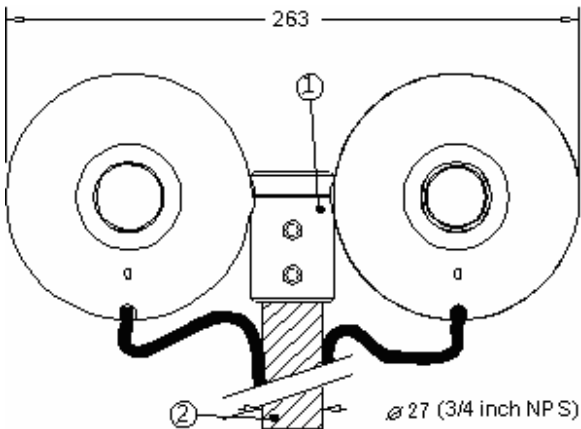

Figure 2 RA01 top view. Standard cable length is 5 m. Cable can be installed / replaced by the user. Attachment to a 1 inch tube (2), not included, is extremely easy, levelling possibilities are included. Dimensions in mm.

RA01 is a 2-component radiation sensor that is used for scientific-grade energy balance studies. The instrument has separate measurements of solar (Short Wave or SW) and Far Infra-Red (Long Wave or LW) radiation. Combined with estimates of SW solar albedo- and of surface temperature, this instrument can also be used for estimation of net-radiation. The advantage in this approach are reduction of costs and independence from local surface properties.

RA01 serves to measure 2 separate components of the surface radiation balance. Working completely passive, using a thermopile sensors, generates 4 small output voltage proportional to the incoming solar SW and LW flux. The solar radiation sensor is also called pyranometer, the LW sensor is also called pyrgeometer. For calculation of sky- and surface temperature, a thermister temperature sensor is included in the pyrgeometer.

In order to avoid deposition of dew, the pyrgeometer may be heated. A 2-axis levelling assembly is included.

The RA01 cable can easily be installed or replaced by the user.

See also NR01 4-component net-radiometer, on the previous page, which is a double side version of RA01.

## RA01 SPECIFICATIONS

General:

Temperature range: -40 to +80 °C

Range : 0 to 2000 Wm<sup>-2</sup>

Temperature sensor: Thermister

Temperature sensor: users own preference can be plugged in

Pyranometer (SW):

Pyranometer ISO classification: second class

Spectral range: 305 to 2800 nm

Calibration traceability: WRR

LW Pyrgeometer (LW):

Spectral range: 4500 to 50000 nm

Calibration traceability: NIST

Window heating offset: <15 Wm<sup>-2</sup>

@ 1000 Wm<sup>-2</sup> solar radiation

heating power 5 Watt @12VDC

## OPTIONS

Additional cable length x metres (add to 5m)

Upgrade to NR01

The above specifications are subject to change without further notice